

*Silhouette*<sup>®</sup>

ICONIC EYEWEAR MADE IN AUSTRIA. SINCE 1964.

Mod. 5518



TITAN MINIMAL ART  
THE ICON. ACCENT RINGS

# CHASSIS

GARNITUR / KIT



Frame made of High-Tech Titanium with parts of SPX®+  
 Brillenfassung aus High-Tech Titan mit Teilen aus SPX®+  
 Monture en High-Tech Titan avec parties en SPX®+

Chassis without accent ring 5097 - please order separately.  
 Garnitur ohne accent ring 5097 - bitte separat bestellen.  
 Chassis sans accent ring 5097 - à commander séparément.



---  
 ---  
 ---



---  
 ---  
 ---



17  
 19  
 21



140/145/150  
 140/145/150  
 150/160

# COLOURS

FARBEN / COULEURS

TMA THE ICON. ACCENT RINGS / Mod. 5518



**Col. / 3530**  
ROSE GOLD / AMETHYST

**metal parts:** rose gold silky matte  
**temple ends:** amethyst  
**decoration ring:** rose gold silky matte  
**temple tips:** amethyst matte

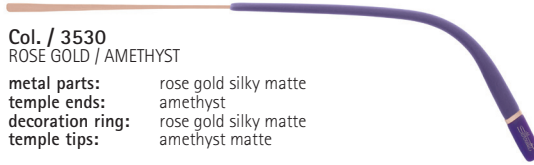

**Col. / 5540**  
BRASS / LIGHT TEAL

**metal parts:** brass silky matte  
**temple ends:** light teal  
**decoration ring:** brass silky matte  
**temple tips:** light teal matte

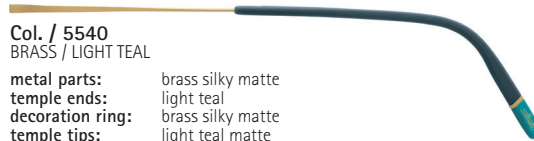

**Col. / 7010**  
COOL GREY / SALMON

**metal parts:** titanium shiny  
**temple ends:** grey  
**decoration ring:** titanium shiny  
**temple tips:** salmon matte

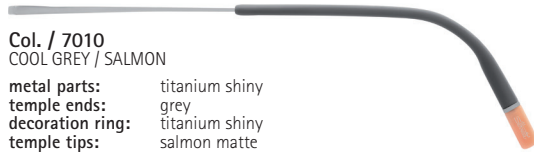

**Col. / 7110**  
COOL GREY / CRYSTAL

**metal parts:** titanium silky matte  
**temple ends:** grey  
**decoration ring:** titanium silky matte  
**temple tips:** grey matte

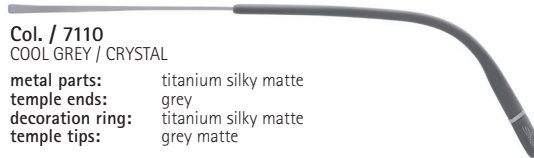

**Col. / 7200**  
RHODIUM / DENIM BLUE

**metal parts:** rhodium silky matte  
**temple ends:** denim blue  
**decoration:** rhodium silky matte  
**temple tips:** denim blue matte

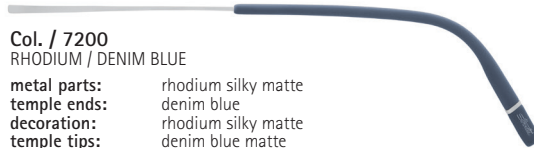

**Col. / 7530**  
GOLD / BLACK

**metal parts:** gold shiny  
**temple ends:** black  
**decoration ring:** gold shiny  
**temple tips:** black matte

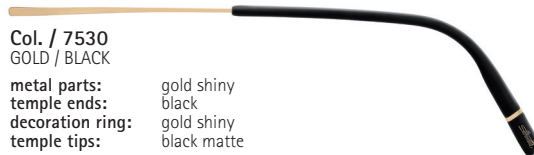





## SHAPES

SCHEIBENFORMEN / FORME







BRASS / LIGHT TEAL  
MOD. 5518/FT-5540

			
54 x 40 (17,63 cm <sup>2</sup> )	60	17	145
56 x 42 (18,96 cm <sup>2</sup> )	62	17	145







COOL GREY / SALMON  
MOD. 5518/FU-7010

			
52 x 41 (15,73 cm <sup>2</sup> )	57	17	140
54 x 42 (16,97 cm <sup>2</sup> )	59	17	140



ROSE GOLD / AMETHYST  
MOD. 5518/FW-3530

			
53 x 40 (16,22 cm <sup>2</sup> )	57	17	140
55 x 41 (17,47 cm <sup>2</sup> )	59	17	140



COOL GREY / CRYSTAL  
MOD. 5518/FV-7110

			
50 x 44 (17,57 cm <sup>2</sup> )	53	19	145
52 x 46 (19,01 cm <sup>2</sup> )	55	19	145







RHODIUM / DENIM BLUE  
MOD. 5518/FY-7200

			
53 x 44 (18,76 cm <sup>2</sup> )	60	17	145
55 x 45 (20,21 cm <sup>2</sup> )	62	17	145









GOLD / BLACK  
MOD. 5518/FZ-7530

			
50 x 39 (15,33 cm <sup>2</sup> )	52	19	140
52 x 40 (16,58 cm <sup>2</sup> )	54	19	140

## ORDER CHASSIS

BESTELLUNG GARNITUR / COMMANDE KIT  
Sortiment / Assortment / Assortiment

entsprechende Version der Garnitur / equivalent version of the chassis / référence du kit correspondant

Mod.	Größe, Size Taille	3530	5540	7010	7110	7200	7530	Chassis, Garnitur, Kit	Größe, Size Taille
5518/FT	54/17 56/17							5518 70	17/145
5518/FU	52/17 54/17							5518 70	17/140
5518/FV	50/18* 52/18*							5518 70	19/145
5518/FW	53/17 55/17							5518 70	17/140
5518/FY	53/17 55/17							5518 70	17/145
5518/FZ	50/19 52/19							5518 70	19/140

\* bridge size is 19

Chassis 5518 / 70: 17/40, 17/45, 17/50  
19/40, 19/45, 19/50  
21/50, 21/60

Chassis without accent ring 5097 - please order separately.  
Garnitur ohne accent ring 5097 - bitte separat bestellen.  
Chassis sans accent ring 5097 - à commander séparément.



Glazed models are only available in one colour and in one size (see above schema).  
Verglaste Modelle sind jeweils nur in einer Farbe und in einer Größe erhältlich (siehe Tabelle oben).  
Les montures percées ne sont disponibles qu'en une couleur et en une taille (voir tableau ci-dessus).

# GROOVED GLAZING

NUT VERGLASUNG / TAILLAGE AVEC RAINURE

## Milling of optical lenses with nylon-groove

Groove-depth:	0,60 mm
Groove-width:	0,80 mm
Basis curve frame:	5
Basis curve lens:	4-6
Minimum thickness of lens rim:	1,8 - 2,0 mm

## Optische Linse mit Nylon-Nut schleifen

Nuttiefe:	0,60 mm
Nutbreite:	0,80 mm
Basiskurve Fassung:	5
Basiskurve Linse:	4-6
Minimale Glasranddicke:	1,8 - 2,0 mm

## Taillage des verres optiques avec rainure nylon

Profondeur de rainure:	0,60 mm
Largeur de rainure:	0,80 mm
Courbure de base de la monture:	5
Courbure de base du verre:	4-6
Verre:	1,8 - 2,0 mm

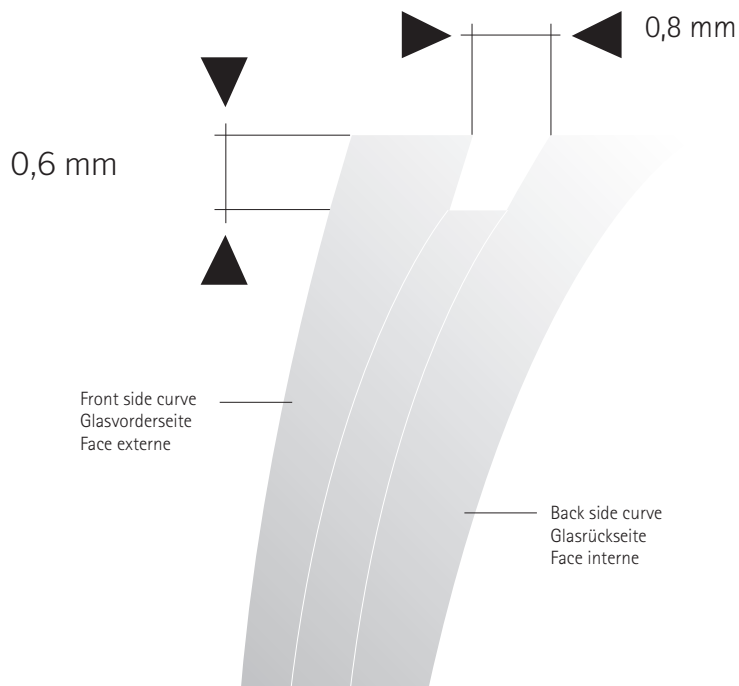

## NEW - NEU - NOUVEAU

The sensation of perfect vision. PREMIUM LENSES MADE BY SILHOUETTE.

Die Sensation perfekten Sehens. HOCHWERTIGE GLÄSER AUS DEM HAUSE SILHOUETTE.

La sensation d'une expérience visuelle parfaitement aboutie. DES VERRÉS HAUT DE GAMME PAR SILHOUETTE.

## SPARE PARTS

ERSATZTEILE / PIÈCES DE RECHANGE

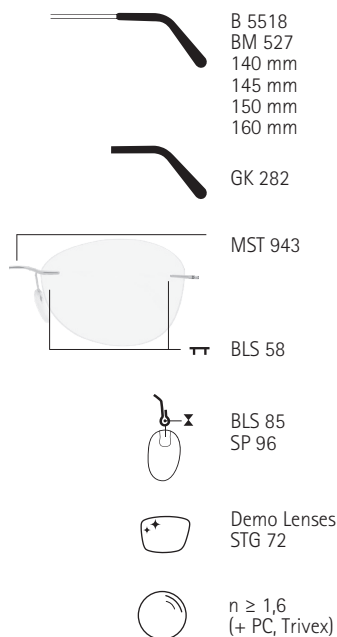

F FT00 54 0000 0000  
F FT00 56 0000 0000

F FU00 52 0000 0000  
F FU00 54 0000 0000

F FW00 53 0000 0000  
F FW00 55 0000 0000

F FV00 50 0000 0000  
F FV00 52 0000 0000

F FY00 53 0000 0000  
F FY00 55 0000 0000

F FZ00 50 0000 0000  
F FZ00 52 0000 0000

We recommend base curve 5, other curves possible.  
Wir empfehlen Basiskurve 5, andere Basiskurven möglich.  
Nous recommandons base 5, autres courbes possible.



SHE 195



P 0036  
Universal-Montage-Box  
universal mounting-box  
boîte de montage universelle



Cleaning cloth PL 30  
Demo: Cardboard Box FK 113-3

VH 85

MH (rubber ring)  
only for shape FV

### Mod. 5518

Metal frame made of High Tech Titanium  
with parts made of SPX®+

Metallfassung aus High Tech Titan  
mit Teilen aus SPX®+

Monture en métal fabriqués en  
High Tech Titanium avec parties en SPX®+

### METAL PARTS SURFACE / OBERFLÄCHEN METALLTEILE / SURFACES METALLIQUES

**Col. 7200**  
rhodium plated, with lacquer finish  
rhodiniert, avec finition vernie  
rhodié, avec finition vernie

**Col. 7010, 7110**  
titanium plated, with lacquer finish  
mit Titan beschichtet, mit Lackfinish  
plaqué en titane, avec finition vernie

**Col. 3530, 7530**  
gold plated, with lacquer finish  
vergoldet, mit Lackfinish  
plaqué-or, avec finition vernie

**Col. 5540**  
with color- and lacquer-finish  
mit Farbfinish und Lackbeschichtung  
avec couleur de finition vernie

specifications are subject to change without notice, no liability will be assumed for misprints  
technische Änderungen und Druckfehler vorbehalten  
sous réserve de modifications techniques et d'erreurs d'impression